

DETAIL 03410-20-A

COBB COUNTY WATER SYSTEM

GREASE TRAP

JULY 23, 2012

Steve McCullers
 AGENCY DIRECTOR
 STEVE MCCULLERS

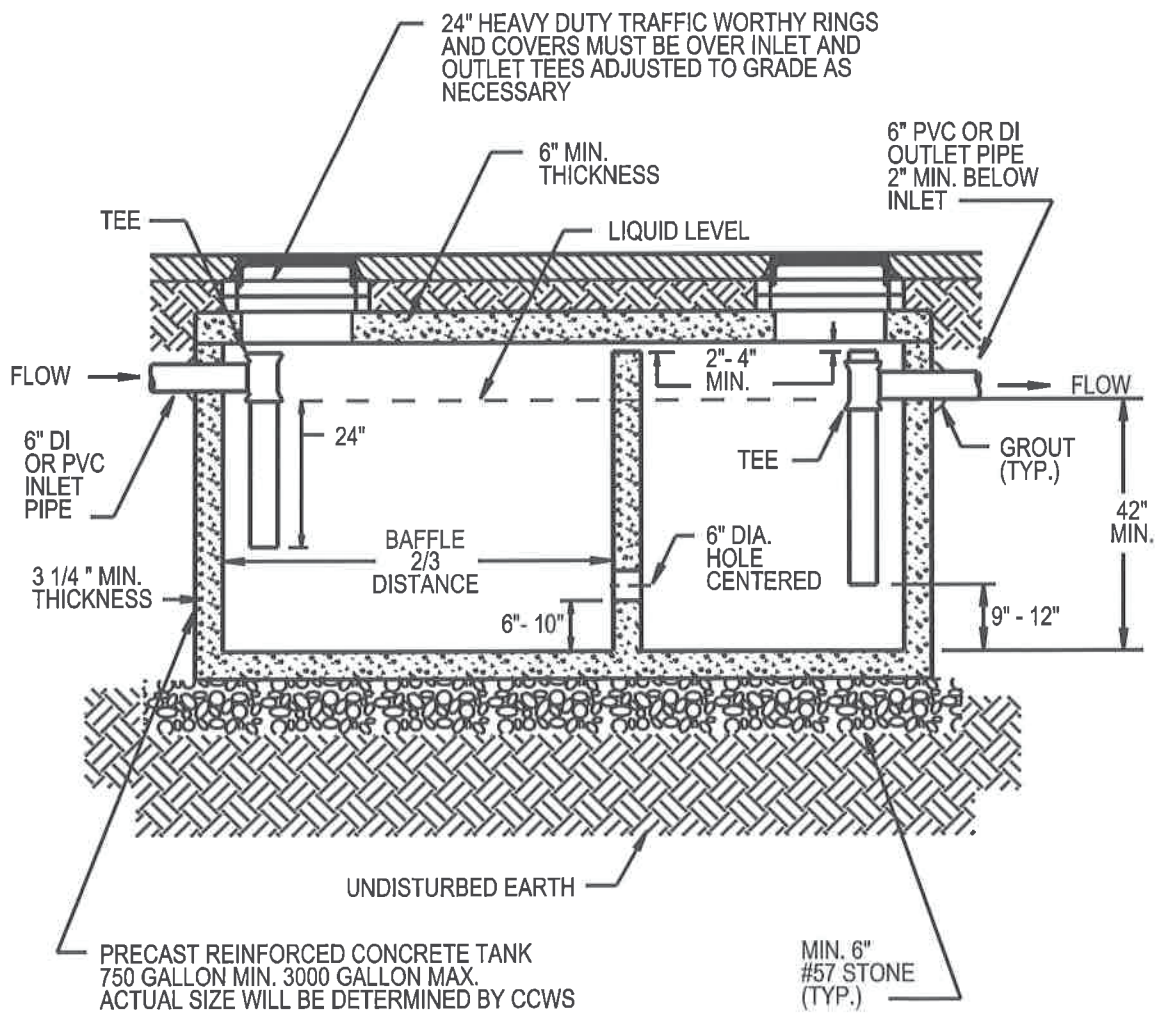

NOTE: INSPECTION BY WATER SYSTEM (ENVIRONMENTAL COMPLIANCE) REQUIRED BEFORE COVERING
 (770) 419-6430